

Safety requirements for using hand-fed platen (die-cutting) machines

HSE information sheet

Printing Information Sheet No 18

Introduction

This information sheet is aimed at all employers, supervisors and managers responsible for the safe operation of hand-fed platen presses. It specifically addresses the risks associated with whole-body access between the platens of larger machines and use of the dwell mode. It also sets out a number of other key issues relevant to machines of all sizes:

- Using the most suitable machine.
- Use of the dwell and continuous mode.
- Existing standards.
- Additional safeguarding requirements if dwell and continuous modes are retained.
- Making the machine safe when accessing the danger area between the platens.
- Training.
- Daily checks.
- Machine inspection.

This guidance has been prepared in response to two fatalities in the UK and three in Germany, Canada and the USA since 2007. All five incidents involved production staff being crushed by the closing platens when the machine was used in dwell mode. The guidance builds on the Safety Alert already issued by HSE and reflects extensive consultation with industry, suppliers and companies who have trialled possible solutions.

What action do I need to take?

Hand-fed platens are high-risk machines. Their use is covered by the Provision and Use of Work Equipment Regulations 1998 (PUWER).¹ The action you need to take to comply with these regulations will largely depend on the size of the machine, together with how it is used. The key test is whether whole-body access between the platens is reasonably foreseeable:

- *Less than 1 m wide* – there is no foreseeable risk of whole-body access. The hazard is mainly hand/arm crush injuries and existing guarding standards are still suitable. However, the guidance on interventions, training, daily checks and periodic inspection will all apply.

- *More than 1.4 m wide* – whole-body access is reasonably foreseeable. There is no need for individual risk assessments to determine this – just follow this guidance in full.

For some hand-fed platens the likelihood of whole-body access may not be clear, so you will need to carefully assess the risks:

- *Between 1 m and 1.4 m wide* – there may be a risk of whole-body access from the front, particularly where access from the side is difficult or obstructed. Your assessment should also take into account the nature of the work and operator behaviour. **If your assessment identifies that whole-body access is reasonably foreseeable, this guidance will apply in full.**

In summary, where there is no risk of whole-body access, there is no need to consider the additional machinery safeguarding requirements detailed below. However, you will still need to review whether hand-fed platens are suitable for your work, the use of dwell and continuous modes and your management arrangements for operating platens safely.

The flowchart at the end of this information sheet presents the same information in an alternative format to aid your understanding and decision making.

Key issues

Using the most suitable machine

The volume and type of work done should determine the best machine for each job. Manually-fed machines like hand-fed platens are generally not suitable for routine high-volume production work. Other machines such as semi-autoplatens or autoplatens (Figure 1) are more suitable for this kind of work. They are also intrinsically safer because there is no need or opportunity for whole-body access and the dangerous parts are fully enclosed by fixed or interlocked guards. Roller presses with fully enclosed dangerous parts (Figure 2) may be suitable for some jobs. The following safeguarding advice should, therefore, be read in the context of these wider production considerations.

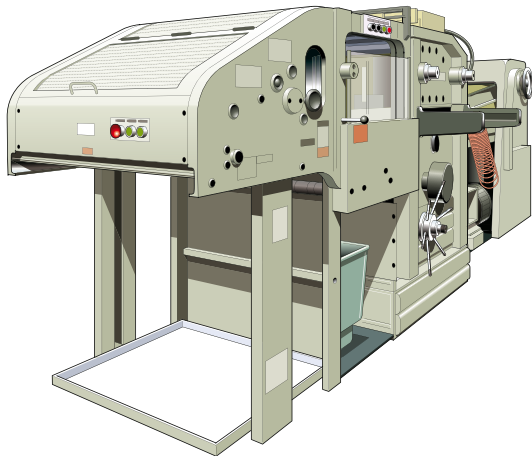

Figure 1 Autoplaten

The use of dwell or continuous modes

If the use of hand-fed platens is appropriate, or will continue as an interim measure, is it necessary to use the dwell or continuous mode? The use of dwell or continuous operation greatly increases the risks of injury. The simplest solution is to physically remove these facilities, ie hardwire them out and use the single-stroke operating mode only. If you do this, then the following existing standards of guarding will be sufficient and none of the *additional safeguarding requirements* described below will be necessary.

Existing standards

Existing standards of guarding are set out in the *Printer's guide to health and safety*² as follows:

- a 'U'-shaped trip guard which closely surrounds the fixed upper platen to within 12 mm on three sides;
- a 'trip bar' or 'pressure sensitive edge' on the front edge of the moving platen; and
- fixed or interlocked side tables, or side guarding in the form of 1 m-wide 'pressure-sensitive mats' extending 250 mm beyond the back edge of the fixed platen.

Note: Where an electro-magnetic or electro-pneumatic clutch is fitted, the control system and guarding circuits should be suitable for a high-risk application, eg dual-circuit cross-monitored.

However, if you retain the dwell and continuous modes and whole-body access is reasonably foreseeable, additional physical safeguards will be necessary. You will need to select the most appropriate solution(s) from the options described below.

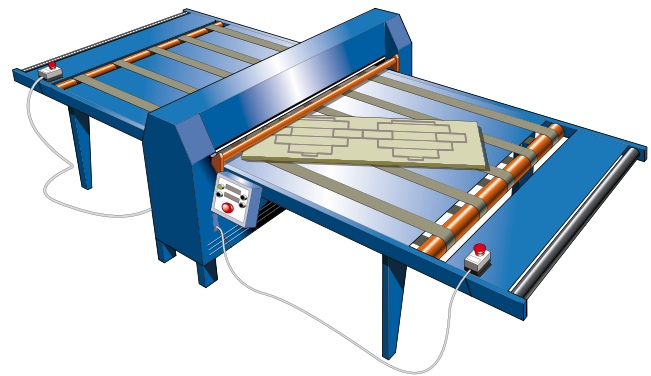

Figure 2 Roller press

Additional safeguarding requirements if dwell or continuous modes are retained

The general principles of safeguarding are:

- to prevent access to the danger area between the platens;
- to detect when access to this area occurs and bring the platen to a stop before harm can occur; or
- to detect a person on the bed of the platen when it is stopped and prevent any movement of it.

The following paragraphs describe a number of options for achieving this which have been developed in consultation with industry. Any other equally effective solutions that might be developed will also be acceptable.

You will need to consider carefully a number of issues to determine which options are the most appropriate for you. These will include:

- the full range of work that is performed on your platen(s);
- how it is currently guarded; and
- how it is used.

The first three illustrations below (Figures 3–5) show examples of *front guarding* options, and for simplicity they are all shown with fixed side guards. The next four illustrations (Figures 6–9) show *side guarding* options for combination with the front guards. The final illustration (Figure 10) shows a *combined front and side* option. In all cases, access from the rear of the machine should be prevented by suitable fixed or interlocked guarding and/or other structures, such as the wall of the building.

Front access

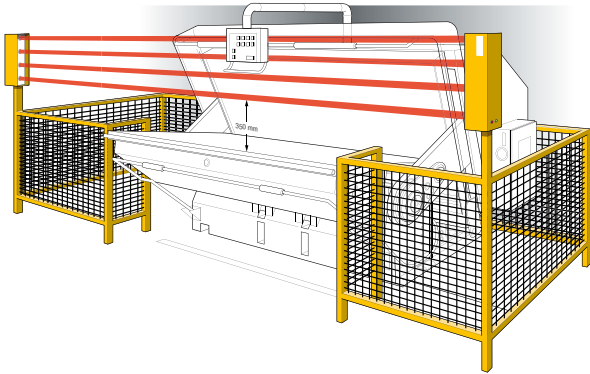

Figure 3 Use Electro-sensitive Protective Equipment (ESPE), for example a light curtain, to detect people entering the danger area. The machine stroke should be arrested in sufficient time to prevent crushing between the platens. To allow for the loading and unloading of work pieces, a maximum opening of 350 mm should be provided between the bottom of the ESPE detection zone and the surface of the movable platen

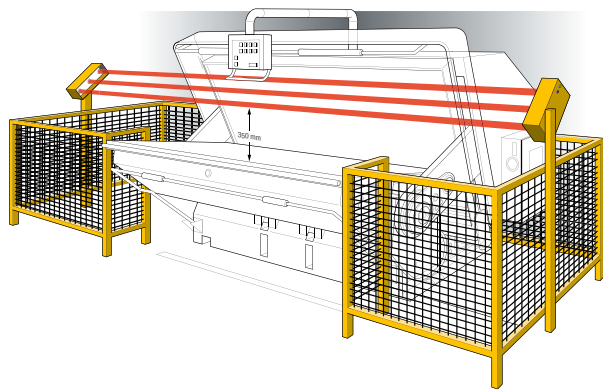

Figure 4 Use ESPE (for example, individual photocells) across the depth and width of the platen to detect people within the danger area and prevent movement of the platen. Individual beams may need to be muted as the platen stroke closes

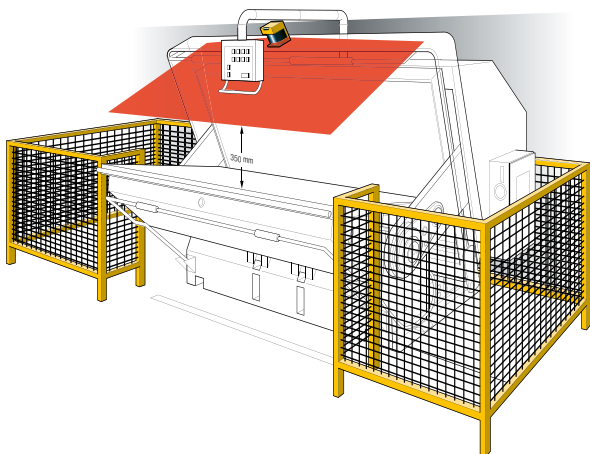

Figure 5 Use ESPE (for example, a laser scanner) to detect people entering the danger area. The machine stroke should be arrested in sufficient time to prevent crushing between the platens. To allow for the loading and unloading of work pieces, a maximum opening of 350 mm should be provided between the bottom of the ESPE detection zone and the surface of the movable platen

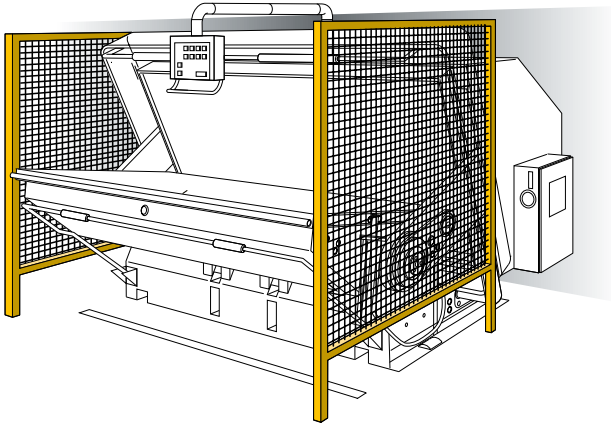

Figure 6 Eliminate access to the machine from the sides by use of *fixed enclosing guards*. The height and dimensions of the guards must be sufficient to prevent reach access to dangerous parts of the platen

Side access

Note: Where fixed guards are used, it is important to ensure there is sufficient clearance between any fixed structure and the moving platen to avoid creating a shearing trap.

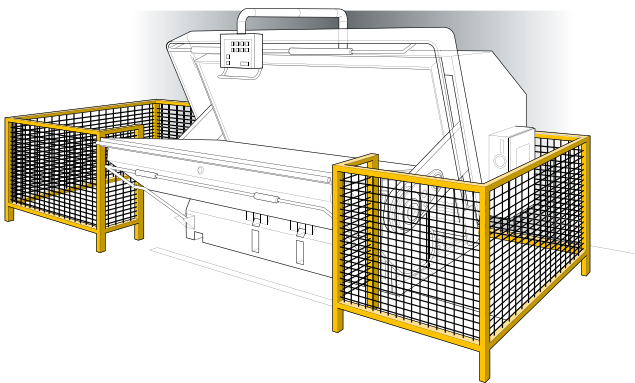

Figure 7 Use a combination of fixed and interlocked guards to form *gated enclosures* to the sides of the machine. The enclosure height and dimensions must be sufficient to prevent reach access to dangerous parts of the platen

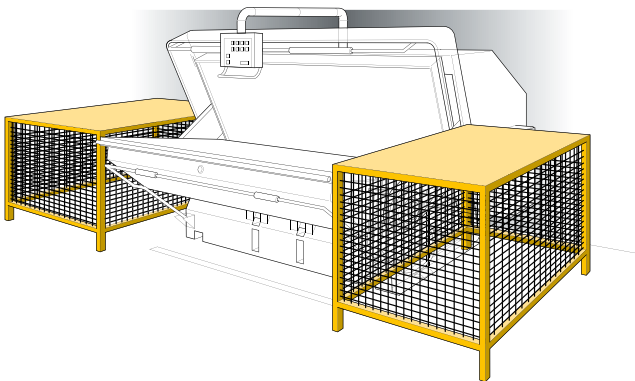

Figure 8 Use fixed or interlocked *side tables* to provide physical distance away from dangerous parts of the platen. Again, the height and dimensions of the tables must be sufficient to prevent reach access to dangerous parts of the platen

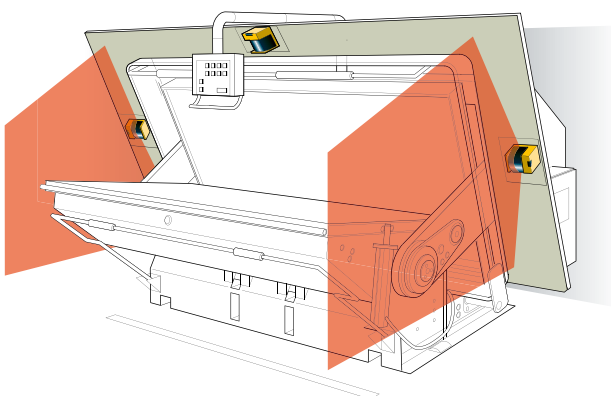

Figure 9 Use of ESPE (for example, laser scanners mounted on each side of the machine) to detect persons entering the danger area. The platen stroke should be arrested in sufficient time to prevent contact (crushing and shearing) with the dangerous parts

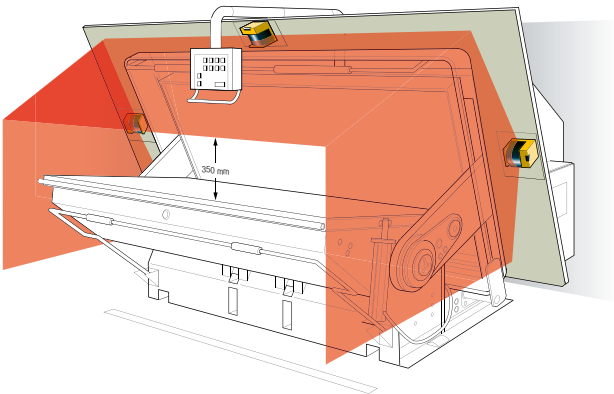

Figure 10 A machine fitted with three laser scanners to control access from *both* front and sides

Making the machine safe when accessing the danger area between the platens

On machines wider than 1 m, operators and setters may need access onto the bed of the platen to carry out a range of tasks, of varying duration. The steps you need to take to make the machine safe during these interventions will depend on the nature and duration of the activity, and will form a key part of your safe systems of work.

- **Short-duration interventions.** Tasks such as retrieving mis-feeds or off-cuts from between the platens take only a few seconds and may occur quite frequently. In such cases, it is acceptable to use the 'cycle-interrupt function' where this is fitted. The cycle-interrupt typically consists of a hard-wired, key-operated, switching device. This should return the machine to standby mode and physically lock-out the clutch mechanism, so that a stroke cannot be initiated. As with other guarding arrangements, this should be suitable for a high-risk application, eg a dual-circuit, cross-monitored system. Alternative stop controls may also be acceptable for this purpose, provided they offer an equivalent level of integrity. Use the isolation controls where no cycle interrupt or equivalent stop control is fitted.
- **Longer-duration interventions.** Tasks such as setting, or maintenance-type activities, will require isolation and lock-off. Isolation requires establishing a break in the energy supply in a secure manner, ie by ensuring that inadvertent reconnection is not possible. All hand-fed platens should have a suitably located electrical isolator switch that de-energises all power to the machine. The switch should include a locking facility, allowing personnel to attach personal padlock(s) to carry out long-duration activities. The isolator should be readily identifiable and easily accessible – the more remote or hard to access it is, the less likely it is to be used. If necessary, the position of the isolator may need to be moved.

Safe systems of work should be established and effectively supervised for both short- and long-duration interventions. Besides detailing the machinery safety requirements, other issues, such as the handling of the product forms, should be considered. It is vital to involve employees in this process because they know how the machines are actually used, they will be able to suggest practical solutions to problems, and they will be more likely to 'buy into' safe systems of work if they have had a part in devising them.

Training

All operators should be properly trained and competent. Training should be based on relevant safe systems of work and should include the basic machine operation, the function and correct use of the controls, how to complete daily checks and what to do if the machine fails any of them or if the operator has any concerns. The training should also clearly identify which tasks an operator should not carry out (ie setting and maintenance) as part of a wider set of 'dos and don'ts'.

Retraining or refresher training for existing staff is important if new safeguarding methods are introduced, and is particularly important if the safe systems of work are changed while the machinery stays the same.

Supervisors have a crucial role in ensuring that operators follow agreed safe systems of work. They also need to be competent to carry out their duties effectively and may themselves require further or refresher training where there are any changes to the way you work.

Daily checks

It is strongly recommended that companies set up a system of daily (or shift) pre-use checks to ensure that the safety devices are working effectively. These checks should be carried out by operators who have had the necessary training. There is no legal requirement to record the checks, but this is also strongly recommended as it demonstrates the importance attached to the checks and assists the supervisors in their work.

Machine inspection

The safety-critical parts on a hand-fed platen should be inspected periodically by a 'competent person' because any deterioration in performance could result in a significant risk to the operator. For machines fitted with ESPE safety devices, this should be every six months. For machines fitted with other safety devices, the advice of the Printing Industry Advisory Committee (in the *Printer's guide to health and safety*) is inspections at least every 12 months. Your insurance company or machine supplier will be able to advise further on this issue.

Hand-fed Platens Flowchart

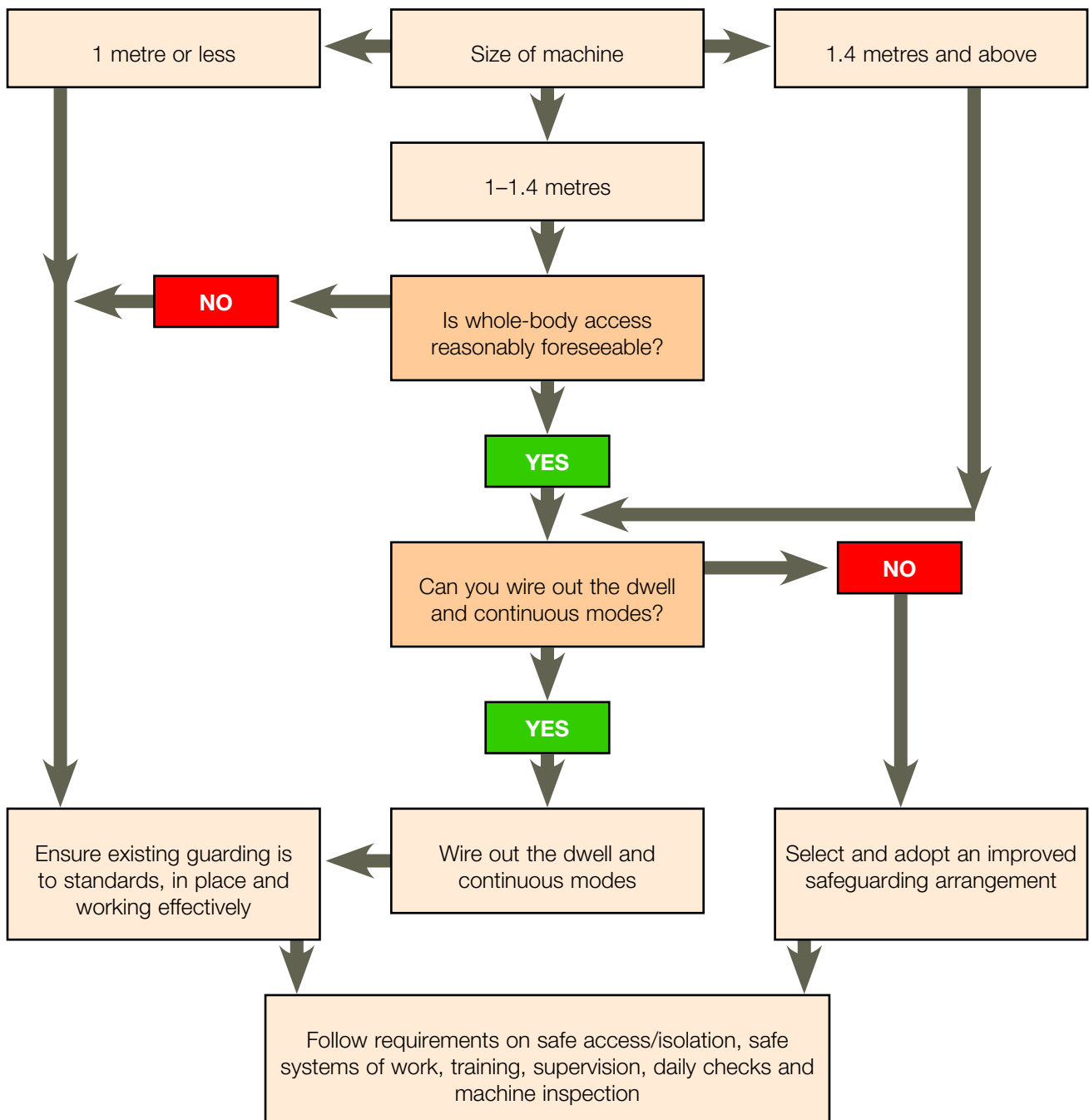

References

1 *PUWER 1998: Provision and Use of Work Equipment Regulations 1998. Open learning guidance* (Second edition) HSE Books 2008 ISBN 978 0 7176 6285 2

2 *The printers' guide to health and safety* (Second edition) HSE Books 2002 ISBN 978 0 7176 2267 2

Further information

More information will be available at www.hse.gov.uk/printing/index.htm and www.hse.gov.uk/paper/index.htm or, alternatively, you can email your query to platens@hse.gsi.gov.uk

HSE priced and free publications can be viewed online or ordered from www.hse.gov.uk or contact HSE Books, PO Box 1999, Sudbury, Suffolk CO10 2WA
Tel: 01787 881165 Fax: 01787 313995. HSE priced publications are also available from bookshops.

For information about health and safety, or to report inconsistencies or inaccuracies in this guidance, ring HSE's Infoline Tel: 0845 345 0055 Fax: 0845 408 9566
Textphone: 0845 408 9577 e-mail: hse.infoline@connaught.plc.uk or write to HSE Information Services, Caerphilly Business Park, Caerphilly CF83 3GG.

© *Crown copyright 2010* If you wish to reuse this information visit www.hse.gov.uk/copyright.htm for details. First published 12/10.